

Flexible measurement of fuel levels

Adjustable Fuel Lever Arm Sender

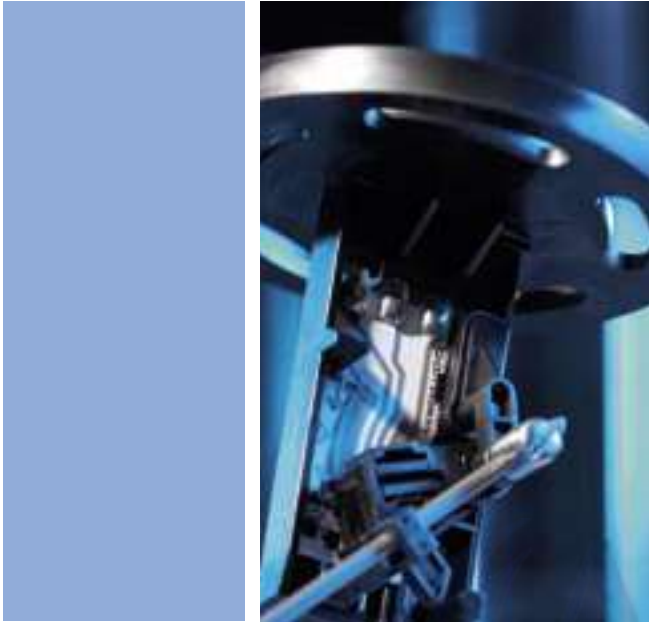

www.siemensvdo.com

To ensure the safe operation of vehicles and machinery it is important to be reliably informed about the current fuel level at all times. Lever-type senders measure the level in the tank and send the information to the corresponding display instrument. An additional reserve function can be set to provide a warning when the fuel level is too low.

A new generation of lever-type senders

Our new, specially developed lever-type fuel senders now offer our customers a robust and particularly flexible way of ensuring reliable fuel measurement for various tank depths.

The system is based on a lever arm, which captures the current fuel level. The length of the lever arm can be adapted to specific requirements and shortened. This makes it possible to equip various tank depths (145 mm to 400 mm) using just one system – an advantage that is particularly attractive with shallow tanks.

Two versions of the adjustable fuel lever arm sender are available – with and without warning contact. The version with integrated warning contact can be hooked up to an external reserve display

that indicates when a defined minimum level has been reached, for example. The lever arm is flexibly supported to compensate for non-level conditions and movement. It has been successfully deployed in the marine sector for many years. This proven, robustly designed technology features a high level of display accuracy and can now be used in many other scenarios, ranging from small engines to agricultural machinery and large stationary machines.

Versatile deployment scenarios

- Small engines and construction machinery (mini-excavators, dumpers, compressors, etc.)
- Agricultural machinery
- Marine applications (sports and leisure boats, jet skis, etc.)
- Two-wheeled machines (motorcycles, scooters, etc.)
- Micro cars, quad bikes
- Stationary machines (generators, compressors, etc.)

This product is available in single packs and in packs of 10.

Technical specifications

Tank depth:

- _ Adjustable from 145 mm up to 400 mm

Rated voltage:

- _ 6 V to 24 V, insulated return

Resistor ranges:

- _ 3 Ω (empty) to 180 Ω (full)
- _ 240 Ω (empty) to 33.5 Ω (full)
- _ 2 Ω (empty) to 90 Ω (full)
- _ Optional warning contact at 15% remaining volume
- _ Measurement resolution in 39 steps
- _ Depending on customer requirements other resistor ranges may be specified

Mounting geometry:

- _ 5-hole flange with 54 mm diameter

Electrical connection:

- _ 6.3 x 0.8 (2x)
- _ 2.8 x 0.8 (1x; for warning contact version only)

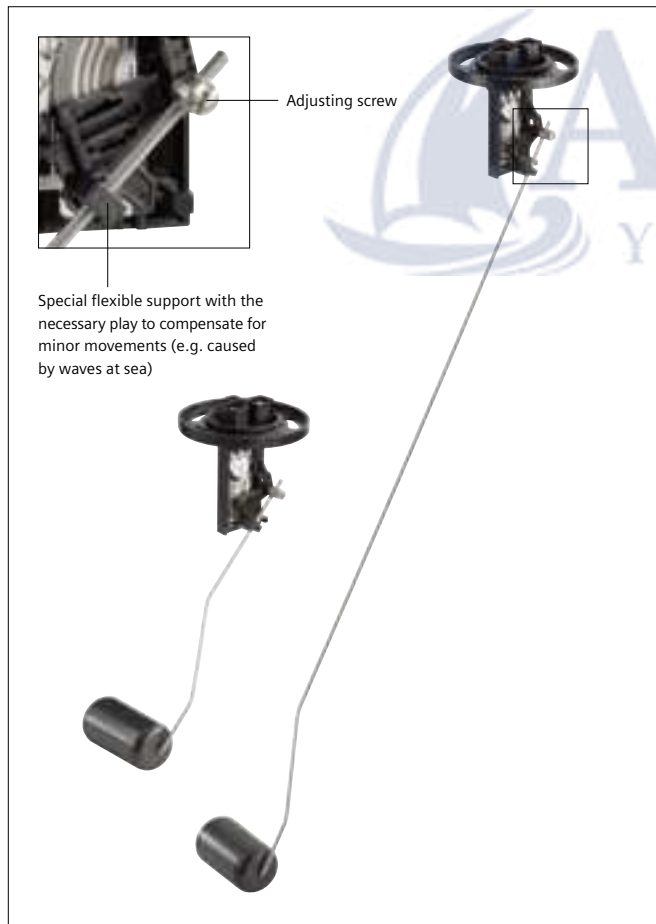

Can be adjusted for tank depths from 145 to 400 mm

Benefits

- _ Adjustable fuel lever arm sensor
- _ Versions with and without warning contact
- _ \varnothing 54 mm – standard flange
- _ 3 different resistor ranges (thick film technology) for operating standard gauges (depending on customer requirements other resistor ranges may be specified)
- _ Support of various tank depths via easily adjusted lever arm
- _ Robust design
- _ Long life, redundant contact system
- _ All metallic parts in stainless steel
- _ Float made from NBR – float will not sink if damaged
- _ Electrical connection protected by socket housings
- _ Flexible mounting geometry using elongated holes
- _ Defined movement of lever arm for extended service life – e.g. protection against wave impact on boats over a long time
- _ Resistor element with an extended lifetime (1 million cycles 'full/empty' in Super unleaded fuel)

Accomplished qualification tests

- _ Ageing in circulated air (DIN EN 60068-2-14)
- _ Temperature cycle/shock (DIN EN 60068-2-14)
- _ Leak tightness with respect to gases
- _ Pressure resistance (test pressure 2.5 bar absolute)
- _ Sealing against dust and water spray (DIN EN 60068-2-14)
- _ Humid heat (DIN EN 60068-2-30)
- _ Salt spray fog (DIN EN 60068-2-11)
- _ Resistance to chemical agents (diesel fuel, FAM test fuel, sealant, central hydraulic system fluid)
- _ Vibration (DIN EN 60068-2-64)
- _ Endurance test
- _ Protection against ignition of surrounding inflammable gases (ISO 8846)



Installation kit (available separately, not supplied)

Adjustable Fuel Lever Arm Sender Sensors



www.siemensvdo.com

Adjustable Fuel Lever Arm Sender Specification

Adjustable Fuel Lever Arm Sender Specification



Adjustable Fuel Lever Arm Sender Specification

| | |
|---|-----------|
| 1. General Description | 3 |
| 1.1 Purpose | 3 |
| 1.2 Component Function | 3 |
| 1.3 Application | 3 |
| 2. Design | 4 |
| 2.1 Dimensions | 4 |
| 2.2 Lever Arm Fixing | 4 |
| 2.3 Resistor Core (Thick-Film Network) | 4 |
| 2.4 Connector | 4 |
| 2.5 Schematic | 5 |
| 3. Interface Description | 6 |
| 3.1 Electrical Interface | 6 |
| 3.1.1 Voltage | 6 |
| 3.1.2 Connector | 6 |
| 3.2 Mechanical Interface | 6 |
| 4. Functional Characteristics | 7 |
| 4.1 Resistance values | 7 |
| 4.2 Warning contact | 7 |
| 4.3 Working space | 7 |
| 5. Strength test | 8 |
| 5.1 Vibration | 8 |
| 5.2 Plug Resilience and Pull-out Strength | 10 |
| 6. Environment / Installation Parameters | 11 |
| 6.1 Medium | 11 |
| 6.2 Temperature Range | 11 |
| 6.3 Installation Parameters | 11 |
| 7. Testing | 11 |
| 8. List of Abbreviations | 12 |
| 9. Warranty Terms | 12 |

Adjustable Fuel Lever Arm Sender Specification

1. General Description

1.1 Purpose

The adjustable lever arm sender measures the fuel level within a closed tank and is connected via an electrical output to a fuel gauge. As an option, adjustable fuel level sensors with an integrated warning contact can be used in order to also indicate whether a certain minimum fuel level has been reached. To support different tank depths both sensor variants are equipped with an adjustable lever arm.

1.2 Component Function

The sensors lever arm and float is hinged to a contact system which in conjunction with a potentiometer creates an ohmic resistance. This ohmic resistance of the open potentiometer depends on the fuel level.

1.3 Application

This document describes the functional, electrical and mechanical characteristics of the adjustable lever arm sender and its requirements on the system (interfaces and environment). The specified adjustable lever arm sender is a component of the engine management system. The interface gauge / the adjustable lever arm sender is also described in this document.



Adjustable Fuel Lever Arm Sender Specification

2. Design

2.1 Dimensions

The major dimensions and the interface dimensions of the adjustable lever arm sender are specified on the customer drawing.

2.2 Lever Arm Fixing

The lever arm fixed to the contact system and flange via a bolt and clamping screw. After the lever arm has been shortened, it can be adapted to the tank dimension via the clamping screw. The contact system is connected to the lever arm and circularly moves on the thick-film network depending the float position. The locking of the retaining clip and lever arm has a defined free travel which compensates minor movements of the lever arm caused by e.g. sea waves. This compensation improves lifetime of the contact system and thick-film network..

2.3 Resistor Core (Thick-Film Network)

The resistor core (comparable to a potentiometer) consists on a ceramic substrate carrier and an applied resistance paste. Depending on the position of the contact system, variable resistance values are submitted.

2.4 Connector

Two contacts (three contacts for warning contact version) for all input and output signals are integrated into the adjustable lever arm sender. The connector version and the pin configuration is specified in the manual. In case the sensor is not connected the contact tabs are protected with socket housings. Slots in the socket housings prevent contact corrosion as water is directly led outside.

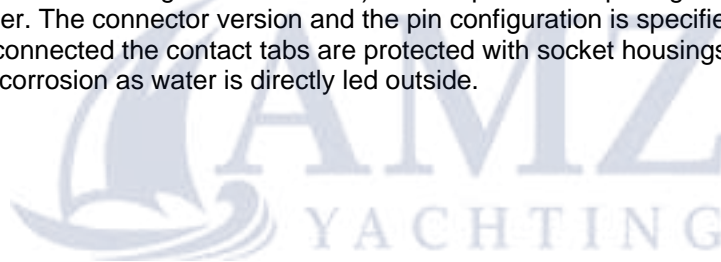

Adjustable Fuel Level Arm Sender Specification

2.5 Schematic

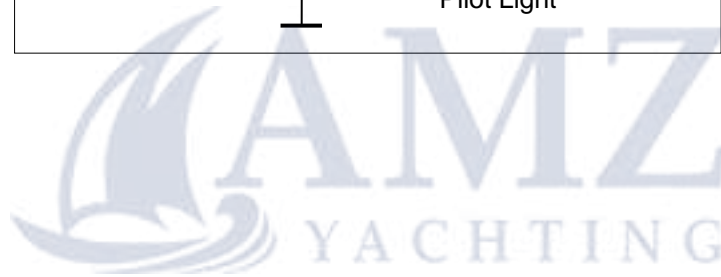
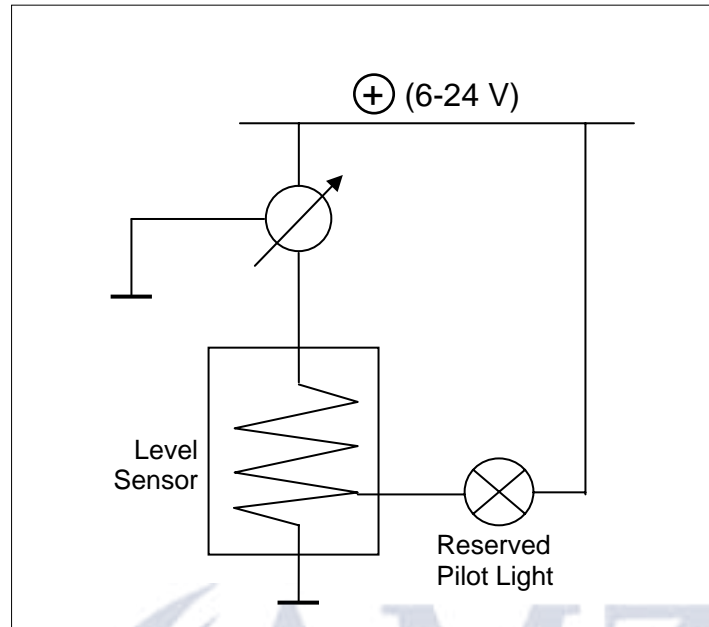

Adjustable Fuel Lever Arm Sender Specification

3. Interface Description

3.1 Electrical Interface

The adjustable lever arm sender is connected to the gauge. The position of the lever arm with the float is displayed on the gauge.

In order to avoid damage caused by mishandling of the adjustable lever arm sender the following requirements and specifications must be considered:

3.1.1 Voltage

Operating Voltage: 6...28 V

Nominal Voltage: 12/24 V

3.1.2 Connector

- Gauge/signal 6,3x0,8 DIN 46247 (blade terminal)
- Ground 6,3x0,8 DIN 46247 (blade terminal)
- Warning contact 2.8x0,8 DIN 46247 (blade terminal)

3.2 Mechanical Interface

This information is specified in details in customer drawing

| | |
|---------------------|--------------------------|
| mounting geometry | see customer drawing |
| mounting hole Ø | 40 / 60 mm |
| footprint | 71 mm x 71 mm |
| Working inside tank | see the customer drawing |
| connector position | 90° to flange |
| total weight | approx. 0,059 kg |

Adjustable Fuel Lever Arm Sender Specification

4. Functional Characteristics

4.1 Resistance values

| | | |
|--------------|---------------------|--------------------------------------|
| A2C53170769: | 90...2 Ω | (full...empty) |
| A2C53170770: | 33,5...240 Ω | (full...empty) |
| A2C53170771: | 180...2,5 Ω | (full...empty) |
| A2C53170772: | 90...2 Ω | (full...empty, with warning contact) |
| A2C53170773: | 33,5...240 Ω | (full...empty, with warning contact) |
| A2C53170774: | 180...2,5 Ω | (full...empty, with warning contact) |

4.2 Warning contact

Warning contact at ~15% rest volume.
Further details see customer drawing.

4.3 Working space

See customer drawing.



Adjustable Fuel Lever Arm Sender Specification

5. Strength test

5.1 Vibration

One or more functions of the DUT do not perform as specified during exposure to the test parameters but return to normal operation after the end of exposure.

No changes may occur which affect the performance of the DUT (e.g. sealing functions or legibility of lettering and labels).

Vibration

In the vibration test the correct functioning of the DUT under a load similar to practice is tested. Profile and duration of the vibration shall make fatigue obvious. The vibration test is not a wear test.

The DUT shall be mounted in installation position on the vibrator table/sliding table by means of suitable holders. Cables and hose connections as well as related add-on parts shall be properly mounted. Cables and hoses shall be supported in accordance with installation conditions without influencing the DUT.

The specified values refer to directly mounted devices. The acceleration measuring point is the interface between test table and DUT.

Orientation of DUT and test sequence shall be documented in the test report.

As vibration load may occur in the vehicle at low and high temperatures, the vibration load test is performed with a temperature profile acc. to "temperature cycle". Electrical operation as specified in section for the endurance test.

Requirements:

All lines are connected acc. to vehicle installation on instrument.

All functions of the DUT perform as specified and after exposure to the test parameters.

No disturbing noise may occur for any operating type.

Adjustable Fuel Lever Arm Sender Specification

Testing

Aim

In the tank area is a wide band random vibration.

Test

Excitation with wide band random vibrations
 Procedure according to DIN EN 60068-2-64.

Test duration for each spatial axis:

8h

Actual acceleration value:

19.7 m/s²

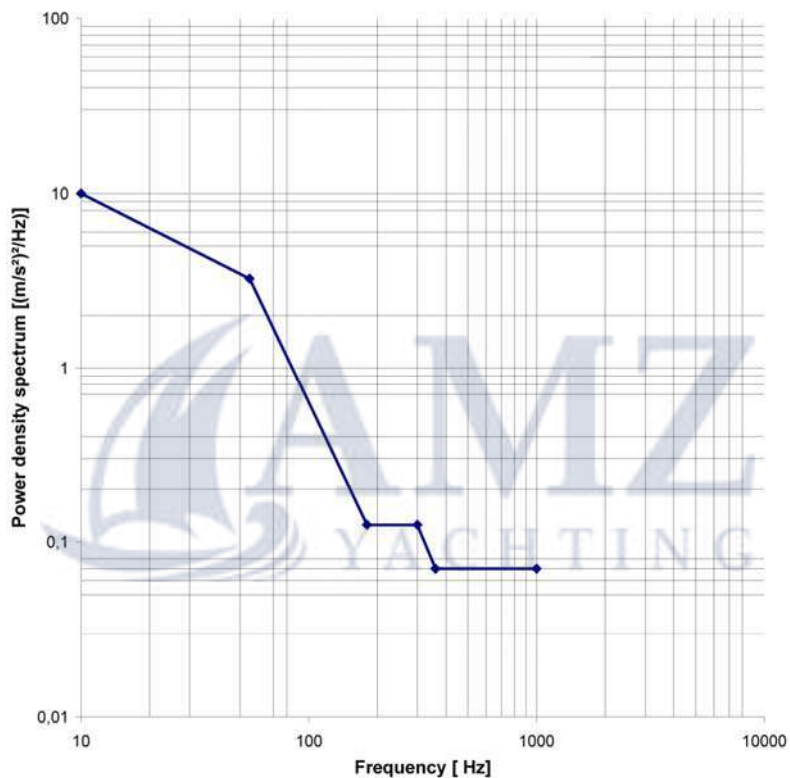

Wide band random vibration profile
Wide band random vibration profile values

| Frequency (Hz) | Power density spectrum decreased by -3dB [(m/s ²) ² /Hz] |
|----------------|---|
| 10 | 10 |
| 55 | 3.25 |
| 180 | 0.125 |
| 300 | 0.125 |
| 360 | 0.07 |
| 1000 | 0.07 |

This document and the information given in connection with said document, in so far it is based on Siemens VDO authorship, are an remain the property of Siemens VDO Trading. This document and all information is confidential. The user is not allowed to disclose it to third parties without having the prior written consent of Siemens VDO Trading. All rights, especially with regard to inventions are reserved by Siemens VDO Trading.

Adjustable Fuel Lever Arm Sender Specification

5.2 Plug Resilience and Pull-out Strength

Plug resilience according to Table Connector types and forces:
Forces shall not be carried by solder points.

Test rate: 100 mm/min

| Flat terminal on the device | Plug resilience/pull out strength |
|-----------------------------|-----------------------------------|
| 6,3 x 0,8 | ≥ 150 N |
| 2,8 x 0,8 | ≥ 80 N |

Resistance to Environmental Factors

The DUT shall not be subjected to any further testing.

Aim

Resistance to environmental factors of the flange is tested.
Test position corresponds to as-installed position.



Adjustable Fuel Lever Arm Sender Specification

6. Environment / Installation Parameters

6.1 Medium

Measured medium is:

| | |
|--------------------------------|---|
| Diesel fuel | acc. to DIN EN 590 and DIN EN 14214 |
| Premium unleaded fuel | acc. to DIN EN 228 (ROZ ≥ 95.0; MOZ ≥ 85.0) |
| Central hydraulic system fluid | acc. to TL 521 46 |

6.2 Temperature Range

| | |
|------------------------|----------------|
| Operating temperature: | -25°C to +70°C |
| Storage temperature: | -40°C to +80°C |

6.3 Installation Parameters

See the customer drawing.

7. Testing

The adjustable lever arm sender successfully passes the following tests:

- Environmental Tests
 - Aging in circulated air (DIN EN 60068-2-14)
 - Thermal Shock Test (DIN EN 60068-2-14)
 - Salt Spray Test (DIN EN 60068-2-11)
 - Humidity Test (DIN EN 60068-2-30)
 - Leak tightness with respect to air
 - Pressure Resistance (DIN 53 758)
 - Sealing against dust and water spray (DIN 40050-9)
 - Plug Resilience and Pull-out strength
 - Resistance to chemical agents
 - Protection against ignition of surrounding flammable gases (ISO 8846)
- Endurance Tests:
 - Life Test (1000h)
 - Vibration test

More specific data on these tests can be supplied on demand.

Adjustable Fuel Lever Arm Sender Specification

8. List of Abbreviations

| | |
|-----|--------------------|
| DUT | device under test |
| IP | impact protection |
| TFN | Thick film network |

9. Warranty Terms

Siemens VDO Trading reserves the right to reject any warranty claims made by the customer pending a thorough investigation of the circumstances.

The limited liability stated in the General Terms and Conditions of Business will have to be taken into account.



Adjustable Fuel Lever Arm Sender Specification

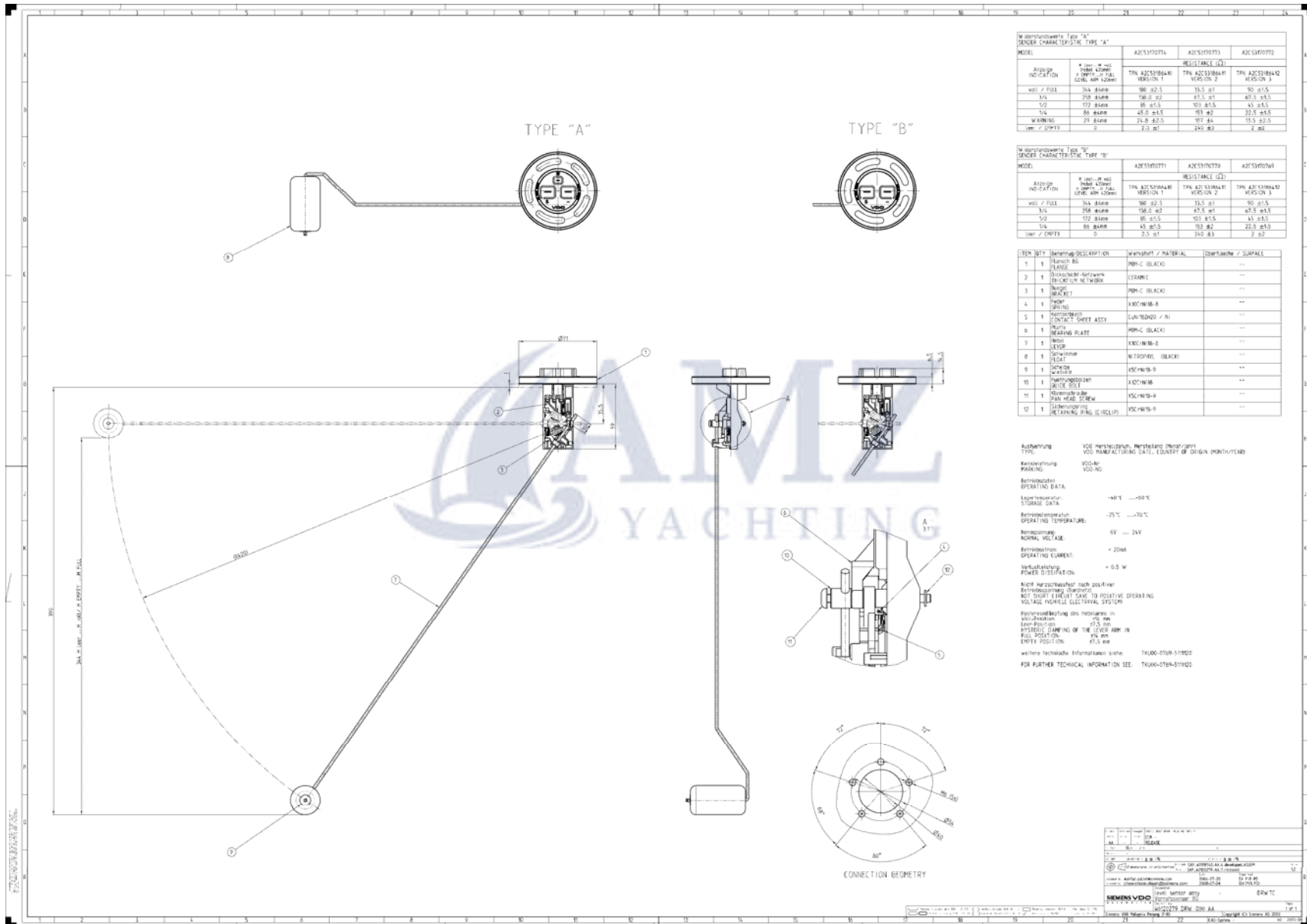

This document and the information given in connection with said document, in so far as it is based on Siemens VDO authorship, are and remain the property of Siemens VDO Trading. This document and all information is confidential. The user is not allowed to disclose it to third parties without having the prior written consent of Siemens VDO Trading. All rights, especially with regard to inventions are reserved by Siemens VDO Trading.

Verstellbarer Kraftstoff-Hebelgeber Adjustable Fuel Lever Arm Sender

TU00-0769-5107120

09/06

1-6

1

Sicherheitshinweise



- Das Produkt wurde unter Beachtung der grundlegenden Sicherheitsanforderungen der EG-Richtlinien und dem anerkannten Stand der Technik entwickelt, gefertigt und geprüft. Das Produkt ist nur für den Einsatz in erdgebundenen Fahrzeugen (ausgenommen Motorräder) oder stationären Anlagen zu verwenden.

Vor dem Einbau beachten:

- Für den Einbau sind Grundkenntnisse der Kfz-Elektrik und -Mechanik erforderlich, um Schäden zu vermeiden.
- Alle Daten von flüchtigen elektronischen Speichern notieren.
- Zündschlüssel vom Zündschloss abziehen. Danach den Minuspol der Batterie (auch von Zusatzbatterien) abklemmen. Beim Abklemmen des Minuspols der Batterie verlieren alle flüchtigen elektronischen Speicher ihre eingegebenen Werte.
- Ein Nichtabklemmen des Minuspols der Batterie kann Kurzschlüsse im Bordnetz verursachen, die Kabelbrände, Batterieexplosionen und Beschädigungen anderer elektronischer Systeme auslösen können.
- Informieren Sie sich vor dem Einbau anhand der Kfz-Papiere über den Fahrzeugtyp und über eventuelle Besonderheiten und anhand von Bauplänen über die Lage von Kraftstoff-, Hydraulik-, Druckluft- und elektrischen Leitungen.
- Das Produkt bestimmungsgemäß einsetzen, nicht verändern oder manipulieren. Die Folgen einer nicht bestimmungsgemäßen Verwendung, einer Veränderung oder Manipulation des Produktes können Personen-, Sach- oder Umweltschäden sein oder die Sicherheit beeinflussen.

Während des Einbaues beachten:

- Auf die Sicherheitshinweise des Fahrzeug- oder Anlagen-, des Motor- und Handwerkzeugherstellers achten!
- Den Einbauort so wählen, dass das Produkt und dessen Komponenten
 - Funktionen des Fahrzeuges oder der Anlage nicht beeinflussen oder behindern.
 - durch Funktionen des Fahrzeuges oder der Anlage nicht beschädigt werden.
 - den Sichtbereich des Fahrers nicht beeinträchtigen.
 - nicht im Kopfaufschlagbereich des Fahrers und des Beifahrers positioniert werden.
 - nicht im mechanischen und elektrischen Airbag-Bereich positioniert werden.
 - genügend Freiraum hinter den Bohrungen oder der Einbauöffnung haben.
- Bohrungen oder Einbauöffnung nicht in tragen-

Nicht rauchen! Kein offenes Feuer oder Licht!
No smoking! No open fire or lights!

de oder stabilisierende Streben oder Holme anbringen!

Nach dem Einbau beachten:

- Massekabel an den Minuspol der Batterie fest anklammern.
- Werte der flüchtigen Speicher neu eingeben/programmieren.
- Prüfen Sie alle (!) Fahrzeugfunktionen.
- Benutzen Sie zum Messen von Spannungen und Strömen im Kfz nur dafür vorgesehene Multimeter oder Diodenprüflampen. Die Benutzung herkömmlicher Prüflampen kann die Beschädigung von Steuergeräten oder anderer elektronischer Systeme zur Folge haben.

Sonderfälle:

- Falls notwendige Arbeiten am laufenden Motor erforderlich sind, besondere Vorsicht walten lassen. Tragen Sie nur entsprechende Arbeitskleidung, da Verletzungsgefahr durch Quetschungen und Verbrennungen besteht. Tragen sie bei langen Haaren ein Haarnetz.

Safety Instructions



- The product was developed, manufactured and inspected in compliance with the basis safety requirements of the EC Directives and in accordance with the generally recognised present level of technology. The product must only be used for service in vehicles restricted to the ground (with the exception of motorcycles) or in stationary systems.

Prior to installation of the product, please observe the following instructions:

- For proper installation of the product, basic knowledge of motor vehicle electrical and mechanical equipment is required in order to prevent damage.
- Write down all the data of volatile electronic memories.
- Remove the ignition key from the ignition lock. Then disconnect the minus pole of the battery (including the minus pole of any auxiliary batteries). When the minus pole of the batteries are disconnected, all volatile electronic memories lose their input values.
- Failure to disconnect the minus pole of the battery can cause short-circuits in the vehicle electrical system and then result in cable fires, battery explosions and damage to other electronic systems.
- Prior to installation of the product, refer to the motor vehicle registration documents for infor-

mation on the vehicle type and any special equipment features and refer to the design plans for further information on the positions of fuel, hydraulic, compressed-air and electrical lines.

- Use the product as intended. Do not change or modify. Improper use, alteration or modification of the product can result in injuries, property damage or environmental damage or have an effect on safety.

During installation of the product, please observe the following instructions:

- Observe the safety instructions of the manufacturers of the vehicle, system, motor and tools in each instance!
- Select the installation location so that the product and its components:
 - do not affect or hinder any functions of the vehicle or system.
 - are not damaged by any functions of the vehicle or system.
 - do not obstruct the driver's view.
 - are not positioned in locations where the driver and front-seat passenger can strike their heads in case of an accident.
 - are not positioned in the mechanical and electrical airbag area.
 - have sufficient clearance behind the drilled holes or installation opening.
- Do not make drilled holes or installation openings in supporting or stabilising braces or struts!

Following installation of the product, please observe the following instructions:

- Connect the ground cable firmly to the minus pole of the battery.
- Enter / program the values of the volatile memories again.
- Check all (!) vehicle functions.
- When measuring the voltages and currents in the vehicle, only use multimeters or diode testing lamps that are designed to be used for such measurements. The use of conventional testing lamps can cause damage to the control units or other electronic systems.

Special cases:

- Please be extremely careful whenever you must perform any required work on the running motor. Wear suitable working clothes only, since risk of suffering injuries such as bruises or burns exists. If your hair is long, wear a hairnet.

Elektrischer Anschluss

Schließen Sie die Kabel entsprechend dem elektrischen Anschlussplan an. Falschanschlüsse können zu Kurzschlüssen führen!

Sicherheitshinweise:



- Kurzschlussgefahr durch fehlerhafte Verbindungsstellen oder gequetschte Kabel! Deshalb müssen alle Verbindungen der Spannungsversorgung entweder weich verlötet oder mit verschweißbaren Stoßverbindern versehen und ausreichend isoliert sein. Andere Verbindungen können Sie mit handelsüblichen Quetschverbindern herstellen. Besonders auf einwandfreie Masseverbindungen achten! Nicht benötigte Kabelenden unbedingt isolieren!
- Kabelquerschnitt beachten! Eine Verringerung des Kabelquerschnittes führt zu einer höheren Stromdichte. Dies kann zu einer Erhitzung des betreffenden Kabelabschnittes führen!
- Abisolierung von Kabeln nur mit einer Abisolierzange vornehmen. Die Zange so einstellen, dass dabei keine Litze beschädigt oder getrennt werden!
- Quetschverbindungen nur mit einer Kabelquetschzange vornehmen.
- Bei der Kabelverlegung vorhandene Kabelkanäle und Kabelstränge benutzen, jedoch nicht die Kabel parallel zu Zündkabeln oder zu Kabeln, die zu großen Stromverbrauchern führen, verlegen! Fixieren Sie die Kabel mit Kabelbändern oder Klebeband!
- Achten Sie darauf, dass die Kabel keinen Zug-, Druck- oder Scherkräften ausgesetzt sind!
- Wenn die Kabel durch Bohrungen geführt werden, schützen Sie die Kabel mittels Gummitüllen oder ähnlichen Teilen.

Electrical Terminal Connection

Connect the cables according to the electrical terminal connection diagram. Incorrect terminal connections can result in short-circuits!

Safety Instructions

- Danger of short-circuits due to defective connecting points or pinched cables! All connections of the voltage supply system must therefore be soft-soldered or provided with weldable joint connectors and sufficiently insulated. You may use commercially available standard-type crimp connectors to make other connections. Make sure the ground connections are perfectly made! Insulate any cable ends that are not required!
- Take the cable cross-sectional area into account! A reduction of the cable cross-sectional area will result in higher current density. This can cause overheating of the affected cable section!
- Cables must be stripped using a wire stripper only. Adjust the wire stripper to prevent any strands from being damaged or cut off!
- Crimped connections must be made using a pair of cable crimping pliers only.
- When installing the cables, use the existing cable conduits and cable harnesses, but do not install the cables parallel to the ignition cables or cables that run over to high-capacity power consumers! Fasten the cables with cable straps or adhesive tape!
- Make sure the cables are not subjected to pulling, pressing or shearing forces!
- If the cables are run through drilled holes, protect the cables by means of rubber sleeves or similar parts.

Verstellbarer Kraftstoff-Hebelgeber
Adjustable Fuel Lever Arm Sender

TU00-0769-5107120

09/06

1-6

2

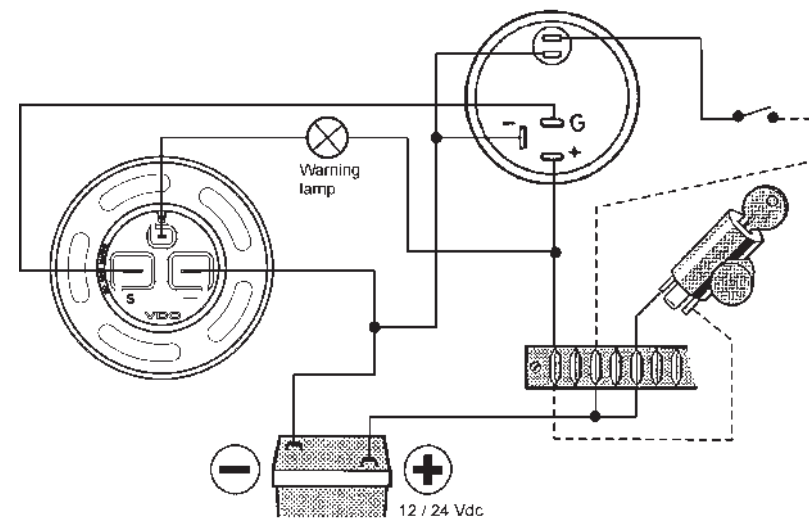
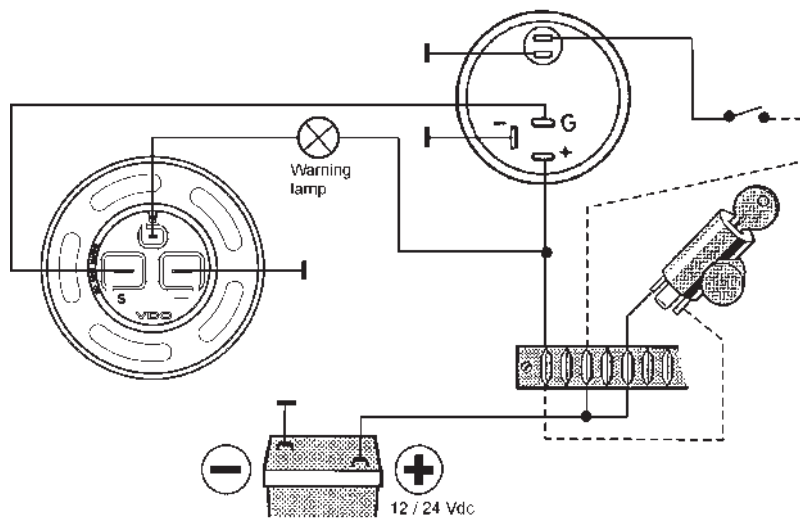
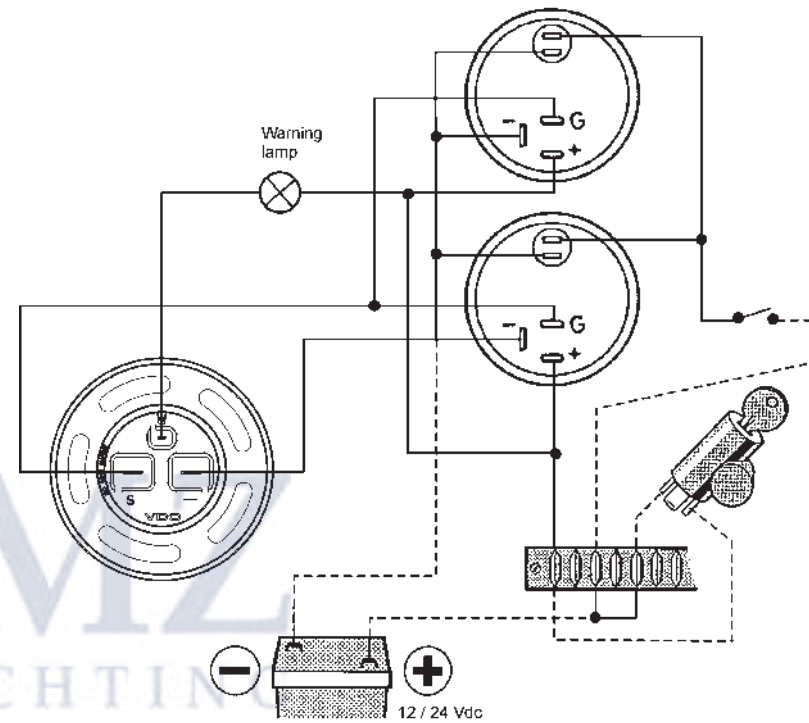
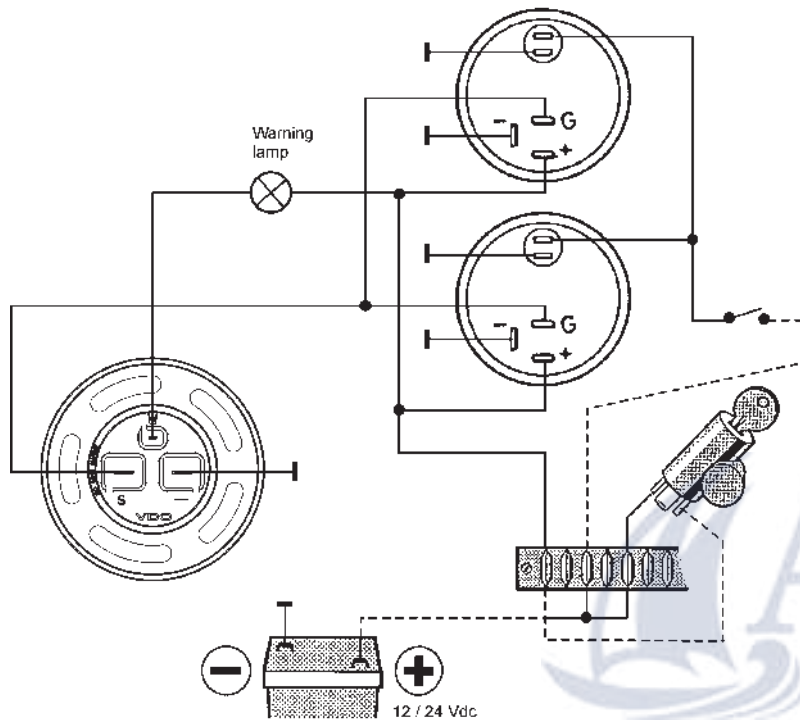

TU00-0769-5107120

Verstellbarer Kraftstoff-Hebelgeber
Adjustable Fuel Lever Arm Sender

TU00-0769-5107120

09/06

1-6

3

Bei Montage bitte Arbeitsschritte ❶ bis ❸ beachten. / While mounting please pay attention to work steps ❶ to ❸.

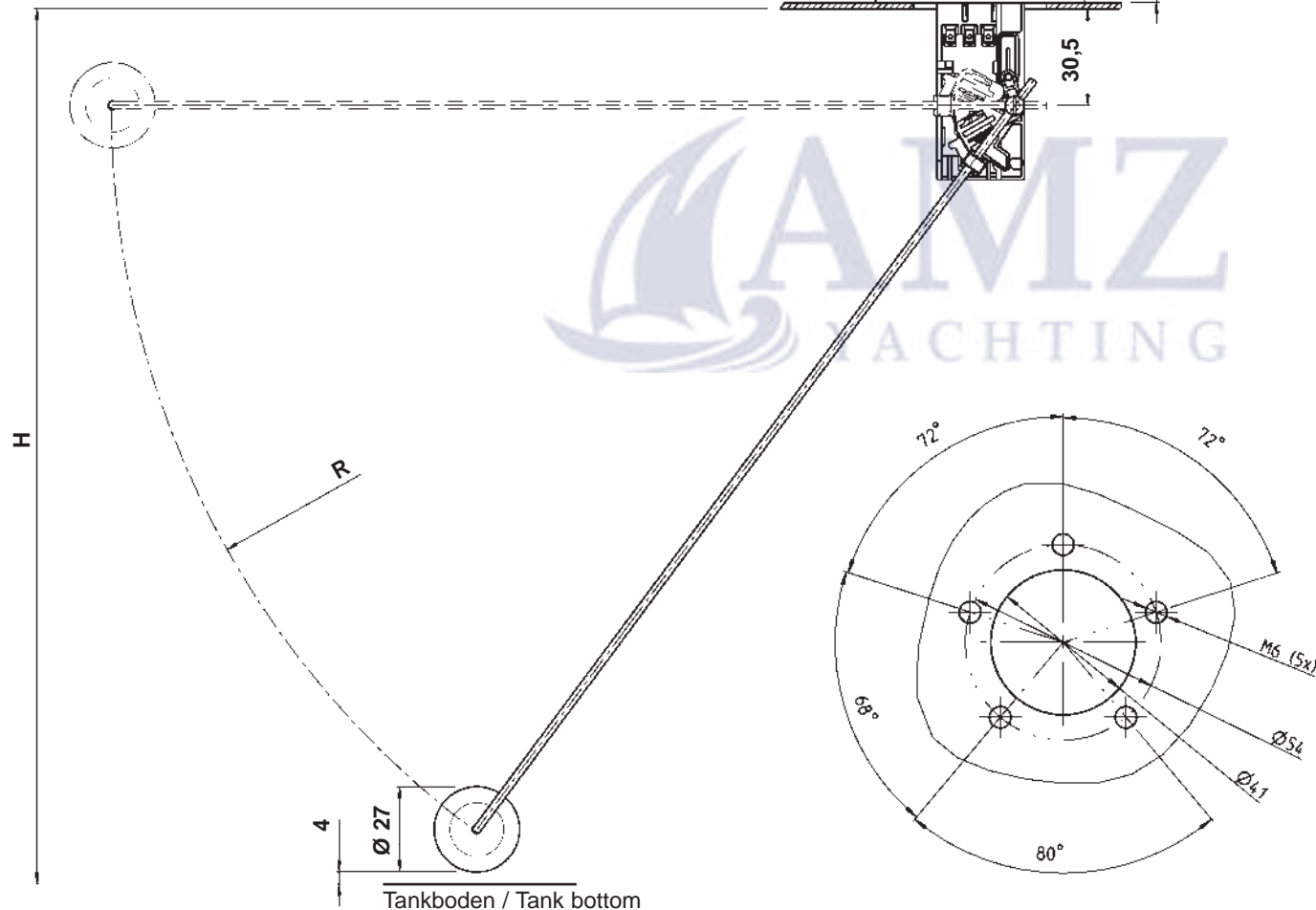
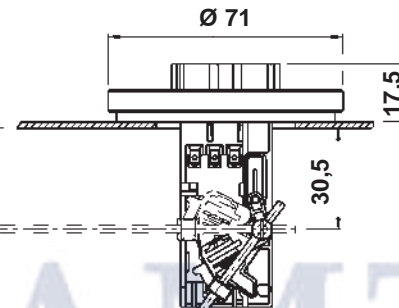
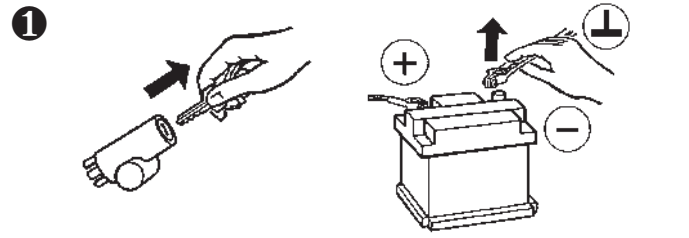

Gebereinbauort

Eine noch herzustellende Montageöffnung im Tank an einer günstigen Stelle für die Vorratsmessung oder ein vom Tankhersteller schon vorgesehener Montageflansch oder eine schon vorgesehene Montageöffnung.

Sicherheitshinweise:



Muss eine Montageöffnung hergestellt werden, ist der Tank vorher vollständig zu entleeren. Den Kraftstoff in einen zugelassenen Behälter füllen. Wenn möglich den Tank ausbauen.

Bei Arbeiten unter dem Fahrzeug die Sicherheitshinweise des Fahrzeugherstellers beachten.

Achtung: Durch Restgase im Tank besteht Explosionsgefahr!
Den Tank mit einem Gebläse gut durchlüften (ca. 10 Minuten).

Montageöffnung mit Bohrer vorbohren und mit Loch- oder Stichsäge fertigstellen. Auf die Sicherheitshinweise des Handwerkerherstellers achten. Tank von Bohr- und Sägerückstände reinigen.

Sensor installation location

An installation opening remaining to be made in the tank at a suitable point for supply level measurement or at an installation flange or installation opening already provided by the tank manufacturer.

Safety Instructions



If an installation opening must be made, the tank must be completely drained first. Fill the fuel into an approved container.

Remove the tank whenever possible. Comply with the safety instructions of the vehicle manufacturer for any work performed under the vehicle.

Caution: Risk of explosion exists due to presence of residual gases in the tank! Make sure that the tank is aired sufficiently (approx. 10 minutes).

Make a preliminary hole in the installation opening using a drill and then finish the hole using a compass saw or piercing saw. Comply with the safety instruction of the tool manufacturer. Clean the tank of residue from the drilling or sawing work.

TU00-0769-5107120

Verstellbarer Kraftstoff-Hebelgeber
Adjustable Fuel Lever Arm Sender

TU00-0769-5107120

09/06

1-6

4

| H | R | H | R |
|-----|-----|-----|-----|
| 395 | 423 | 265 | 275 |
| 390 | 418 | 260 | 270 |
| 385 | 412 | 255 | 264 |
| 380 | 406 | 250 | 258 |
| 375 | 401 | 245 | 252 |
| 370 | 395 | 240 | 247 |
| 365 | 389 | 235 | 241 |
| 360 | 384 | 230 | 235 |
| 355 | 378 | 225 | 230 |
| 350 | 372 | 220 | 224 |
| 345 | 366 | 215 | 218 |
| 340 | 361 | 210 | 213 |
| 335 | 355 | 205 | 207 |
| 330 | 349 | 200 | 201 |
| 325 | 344 | 195 | 195 |
| 320 | 338 | 190 | 190 |
| 315 | 332 | 185 | 184 |
| 310 | 327 | 180 | 178 |
| 305 | 321 | 175 | 173 |
| 300 | 315 | 170 | 167 |
| 295 | 309 | 165 | 161 |
| 290 | 304 | 160 | 156 |
| 285 | 298 | 155 | 150 |
| 280 | 292 | 150 | 144 |
| 275 | 287 | 145 | 138 |
| 270 | 281 | 140 | 133 |

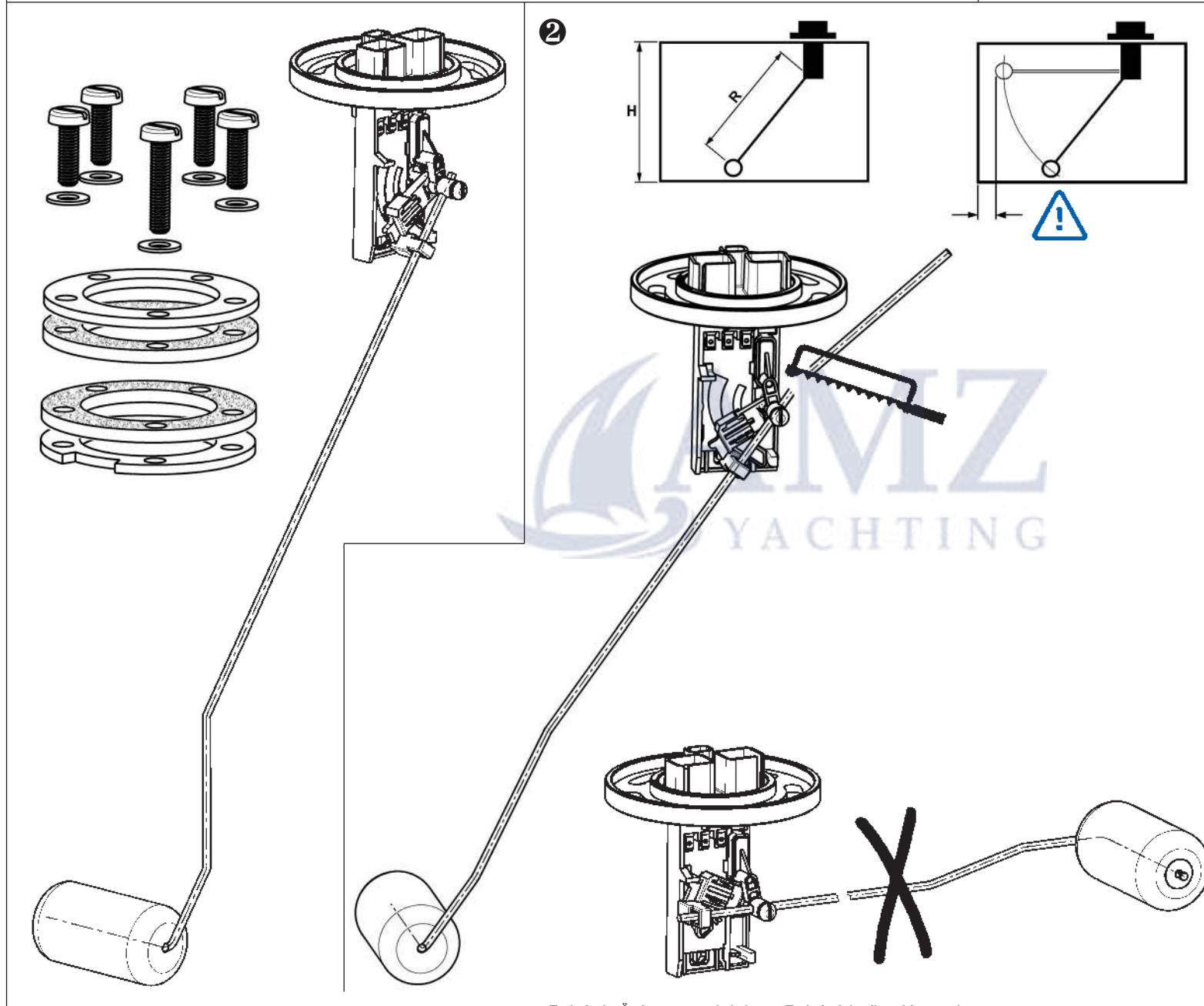

TU00-0769-5107120

Verstellbarer Kraftstoff-Hebelgeber
Adjustable Fuel Lever Arm Sender

TU00-0769-5107120

09/06

1-6

5

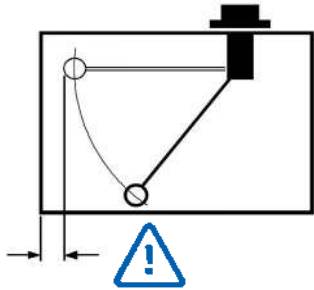

3

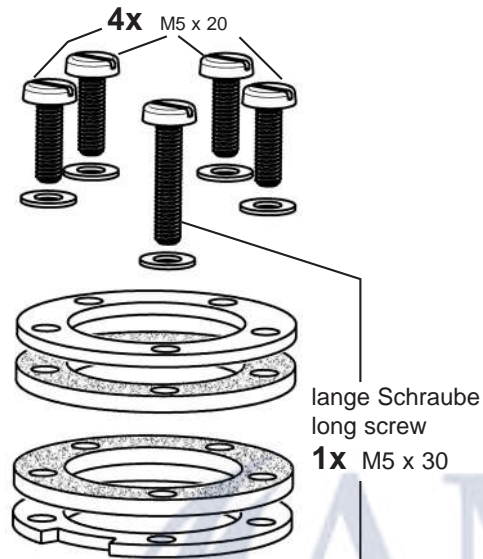
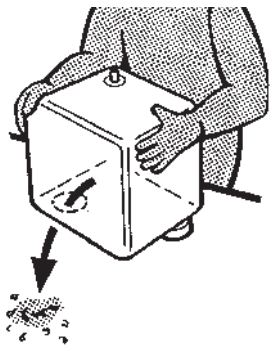
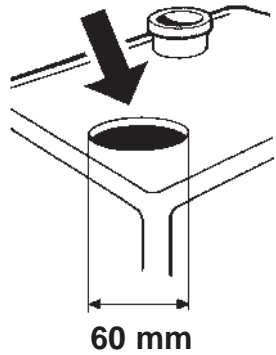

4 a

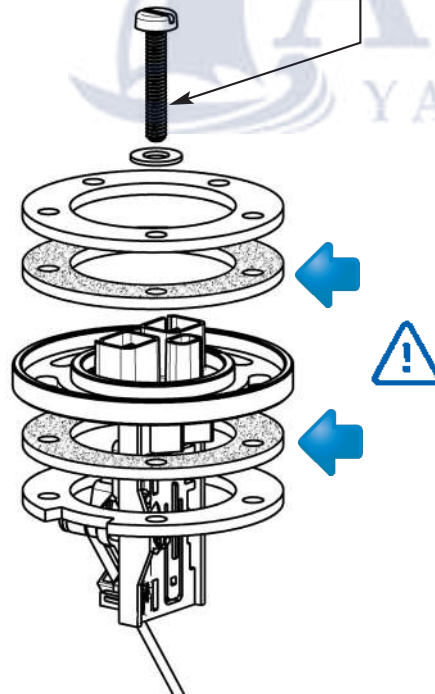

4 b

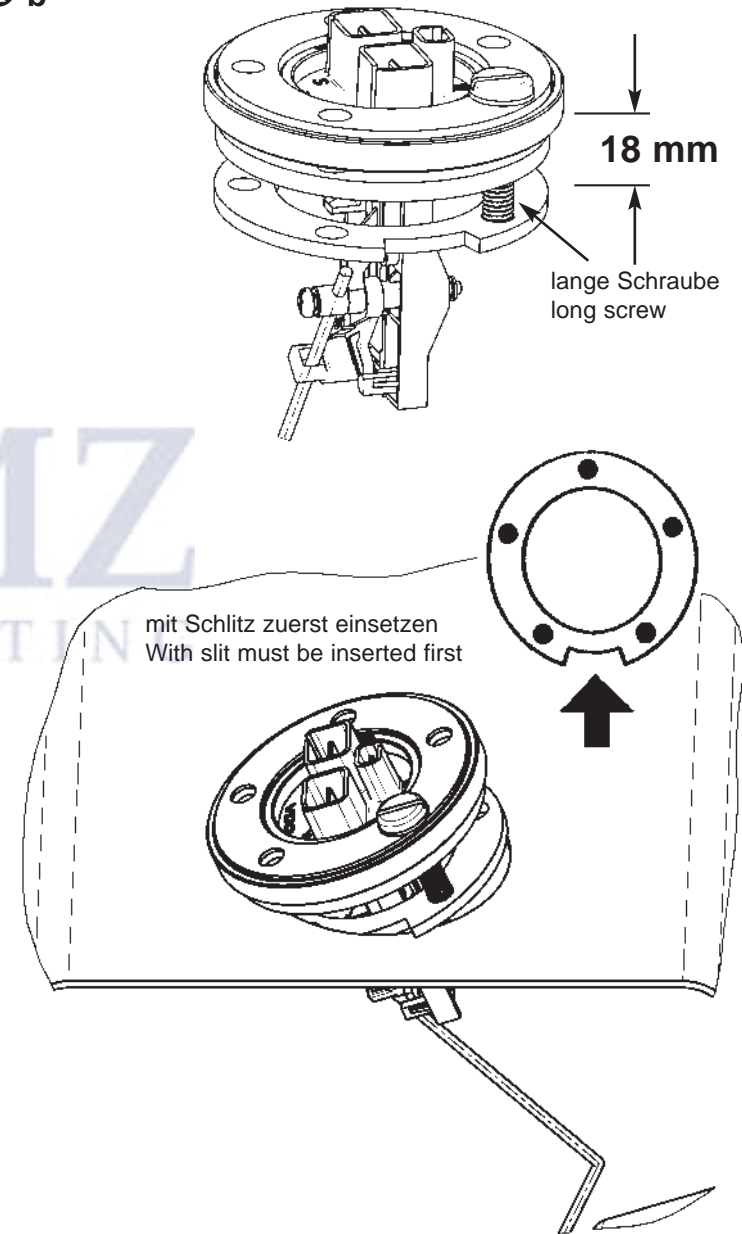

TU00-0769-5107120

Verstellbarer Kraftstoff-Hebelgeber
Adjustable Fuel Lever Arm Sender

TU00-0769-5107120

09/06

1-6

6

4c

oder, or

4

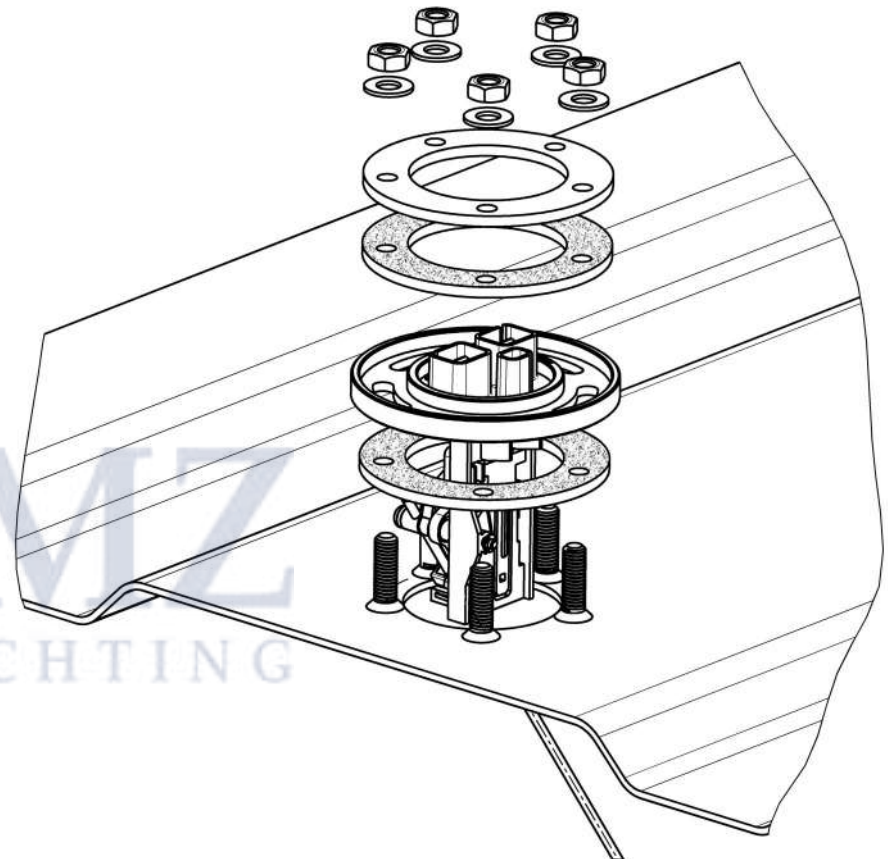
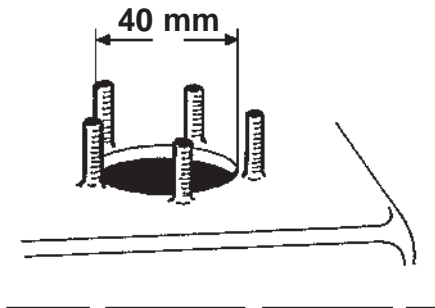
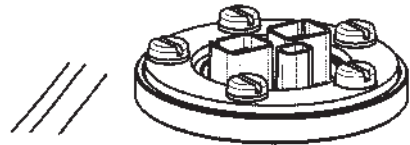
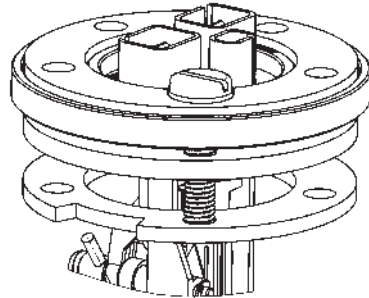
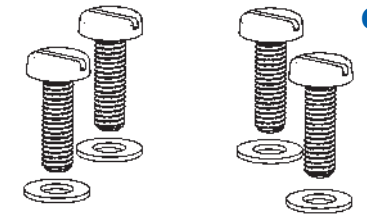

5

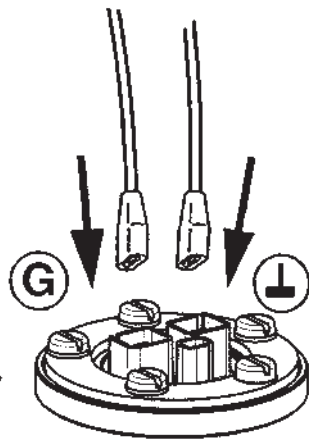

6

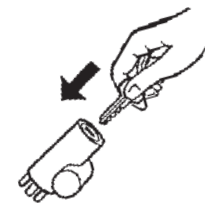
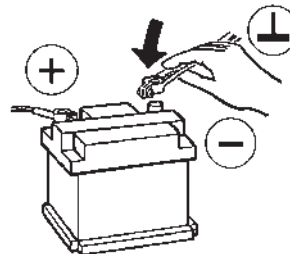

TU00-0769-5107120